

Ax1



Bx1



Cx1



Dx1



Ex1



Fx8



M6X40

Gx1

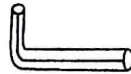

Hx4



M6X18

1

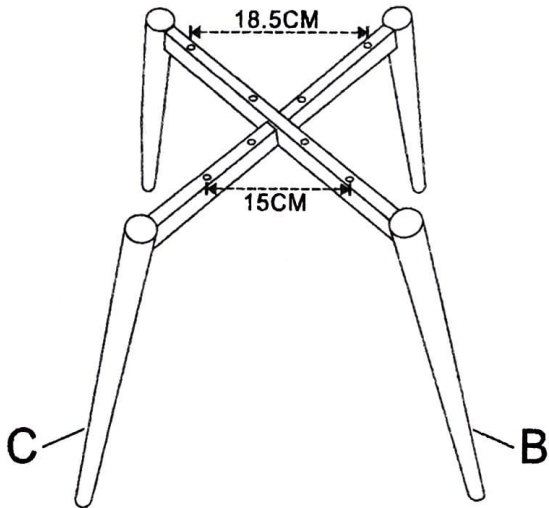

3

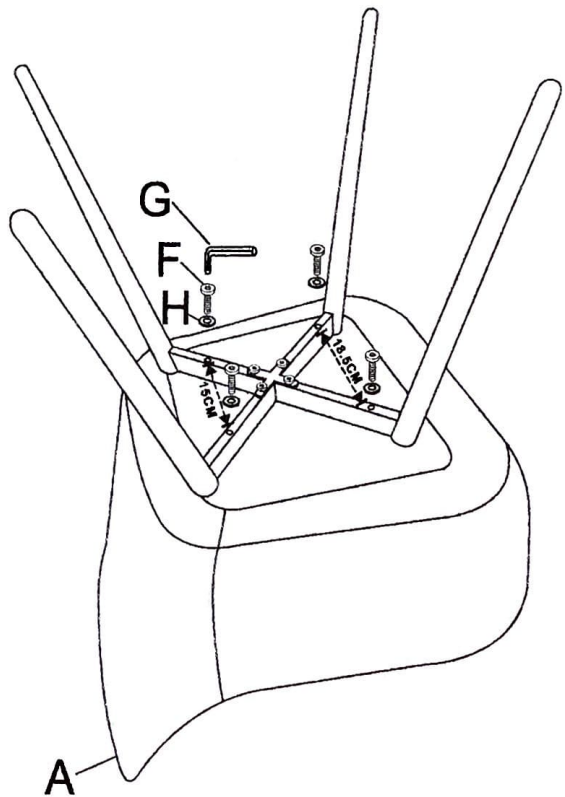

2

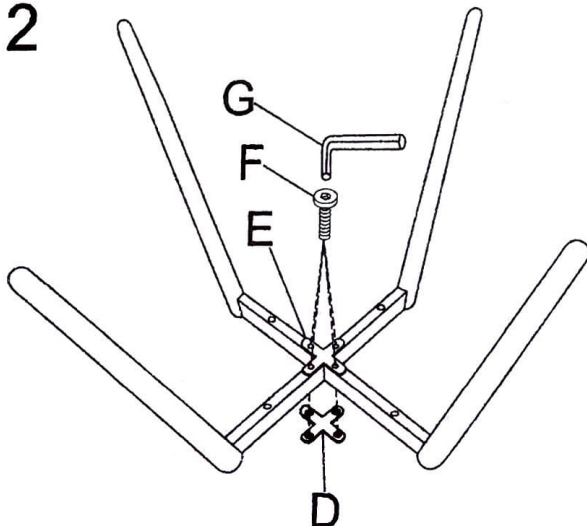

IN THIS STEP  
DON'T TIGHTEN THE SCREWS 100%

AFTER FIX ALL THE SCREWS  
PLEASE TIGHTEN THE SCREWS 100%